

TYPE	HIGH PRESSURE FAN (EXHAUST TYPE)
MODEL	EWF-50FTA40A

VOLUME	
SIGN	

Power supply	Three-phase 400/440 V	Withstand voltage	1900 V AC 1 minute						
Blade type	50 cm metal propeller vane	Insulation resistance	10 MΩ or more (with 500 V Insulation resistance tester)						
Motor type	Totally enclosed 3-phase induction motor (4-pole type E)	Weight	19.4 kg						
Ambient operating conditions	Temperature: -30°C to +50°C Relative humidity: 90% or less (normal temperature) Outdoor use (Inside the projected rain line)	Color	Munsell: 7.65Y7.6/0.7 Body frame, Vane, Motor leg, Motor: Polyester coating						
Ball bearings	Load side: 6203DDW NC Reverse load side: 6203ZZ Grease: Urea	Material	Vane: Steel sheet Motor leg: Flat bar Body frame, Motor: Hot-dip coated steel sheet						
Specifications	Frequency (Hz)	Voltage (V)	Air volume (m ³ /h)	Noise (dB)	Power consumption (W)	Current (A)	Maximum load current (A)	Starting current (A)	Nominal output (W)
	60	400 440	8280 8280	53.5 54	500 510	0.91 0.91	1.28 1.23	6.5 7.02	750

- ※ Air volume and power consumption are measured based on JIS C 9603.
- ※ The values of the noise, power consumption, and current are at a static pressure of 0 Pa.
- ※ The value of the noise is at 1.5 m from the front and both sides of the appliance in an anechoic room. (Average of the three points)
- ※ This appliance is only for exhaust-use.

※ The nominal output is for quick estimate. When selecting a breaker or an overload protection device, refer to the maximum load current value. (Refer to page 2 for details.)

■ Attention

- ※ Refer to the precautions on page 2.

■ Drawings and Dimensions

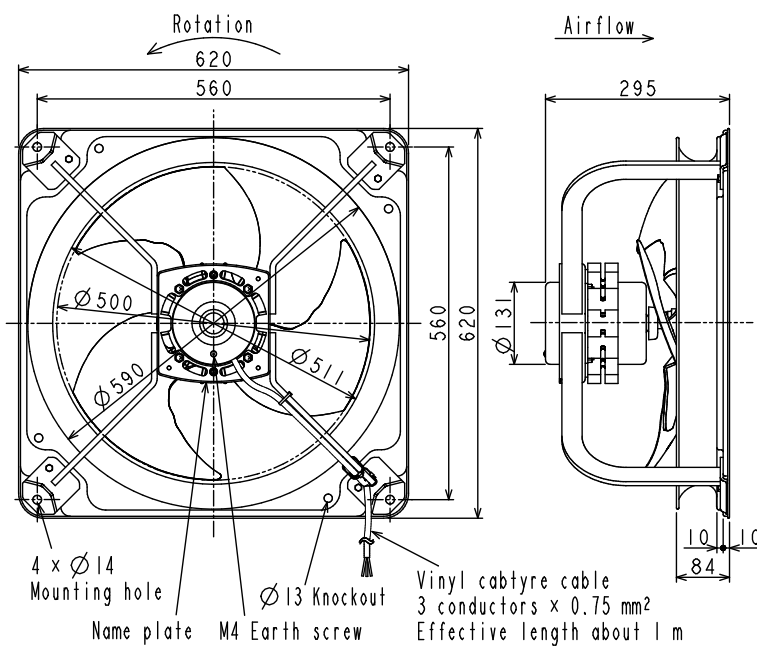

■ Characteristics

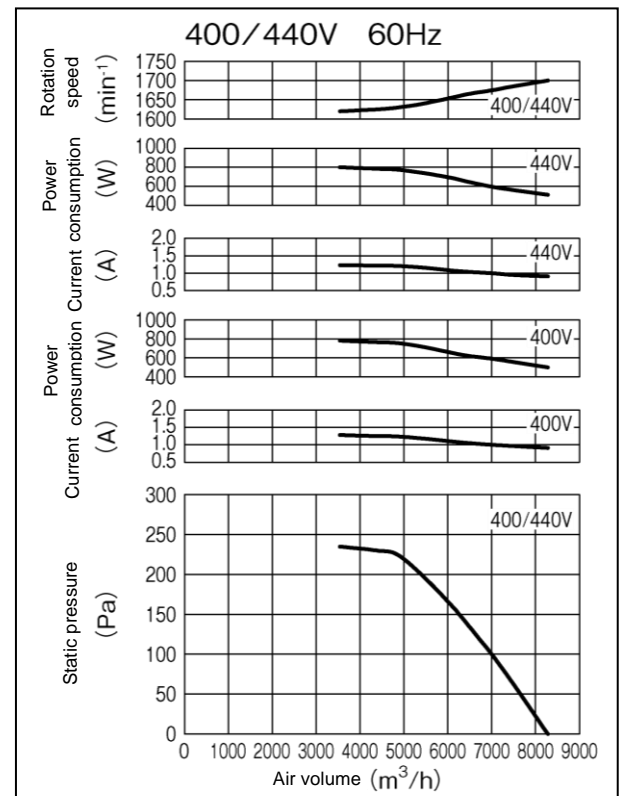

※ The air volume was measured using the orifice chamber method.

■ Connection Diagram

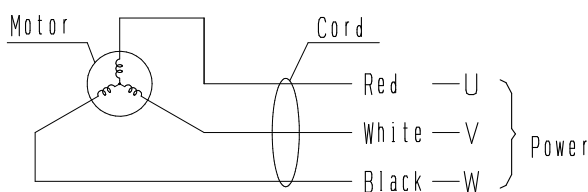

Third Angle Projection Method	Dim. in	Scale	Date	Model	HIGH PRESSURE FAN (EXHAUST TYPE) EWF-50FTA40A
	mm	Non proportional	Oct. 2020		
MITSUBISHI ELECTRIC CORPORATION				Number	NJ014002-60-B (1/2) Specification

TYPE	HIGH PRESSURE FAN (EXHAUST TYPE)
MODEL	EWF-50FTA40A

VOLUME	
SIGN	

■Precautions

1. This appliance is designed for use in Japan only and cannot be used in any other country. No servicing is available outside of Japan.
2. Make sure to keep the periphery of the main body and conveying air at the correct temperature and humidity. Exceeding this range may result in burnout, deformation, defective rotation, or damage to the product.
3. Avoid turning the appliance off and on more than 50 times a day. Otherwise, blade or motor breakages will occur.
4. Do not install the appliance in a place where it will be directly exposed to oily smoke or steam, such as a kitchen.
5. Do not use the appliance in a place where the ambient temperature exceeds 50°C, such as a kitchen. The appliance could stop operating due to the safety device. Besides, deterioration of electric parts including the capacitor and motor could result, or deterioration of bearing grease could result in burnt bearing section.
6. Do not install the appliance in a freezer or a place where freezing is anticipated.
7. Install the appliance in a secure manner in a firm and steady place free from vibrations. Otherwise, resonance could develop, resulting in noises or chipped blades. Reinforce any unstable parts of the mounting location before installing the appliance.
8. The appliance is designed for overhead installation. Install the appliance at a place 1.8m or higher from the floor. Otherwise, injury or accident could result. Even if the appliance is installed 1.8m or more from the floor, when it may touch a human body by work and activity, etc., please install it at the place where a human body doesn't touch for safety.
9. The appliances can be installed right next to another appliance side by side. However, vibration and/or noises may increase on the appliances or the shutter, or the overload protection device may activate depending on the installing condition.
10. Do not install the product in the following places. Resultant drift may cause noises or blade breakage.

① Ducting (No bent ducts on the intake side must be located within distance *D.)

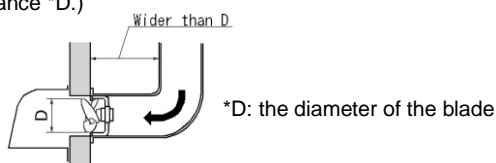

② Places where obstacles exist on the intake side. Places where intake airflow might experience an extreme curvature as shown below.

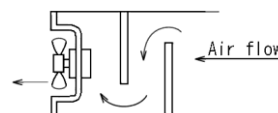

11. Insulate the frame between the appliance and the wooden structure containing metal lath, wire lath, or metal sheets to prevent the structure from contacting directly with the metal part of the appliance. Otherwise, fault current, electric shock, or fire could result. In such a case, the optional insulation frame must be used. (Referring, 'Technical Standards for Electric Systems')
12. Always install a circuit breaker. Failure to heed this warning may result in fire or electric shock.
13. To protect the motor from overloading, install an overload protection device, such as a motor breaker or an electromagnetic switch (or an electromagnetic contactor + thermal relay). An overload protection device must be installed for each appliance. Choose the overload protection device with 1.2 to 1.5 times the maximum load current as a rule of thumb when selecting it.
14. Make sure to secure C-type grounding before installing the fan having an earth terminal or conductor built in. It may cause electric shock.
15. Electrical wiring must be done by a certified electrician in accordance with local standards and regulations. Never twist the stranded wires by hand to connect them. Additionally, connect the power source wires within a metal box for electrical conduits (JIS C 8340).
16. Connecting the power source improperly could hinder correct operation, and could result in a burnt motor or other problem. Securely connect the appliance to the device such as a switch or plug.
17. To discharge unclean air, the appliance requires an opening that takes in fresh air. On the other side of the appliance, provide an air intake opening whose size is the same as or more than that of the frame for the appliance.
18. The appliance tends to become dirty. If dirt left intact for a long time, it will become hard to remove. Clean the appliance ahead of time. (Handle the blade with care.)
19. Modification of the appliance is prohibited as this could result in failure.
20. The appliance can not be used in a salt damage area. Otherwise, rust could develop earlier than usual.
21. The appliance can be installed in a place where it will be directly exposed to rain. (The outdoor-type motor is protected from water at a level corresponding to IPX4 (for the splash-proof type) defined by JIS C 4034-5.) Any rust on the motor could shorten its life, so it is recommended that the appliance be installed inside the rain line (or under the eaves) or a weather cover be used over it.
22. If any flammable substance such as oil or dust accumulates on the appliance, a spark could cause a fire. Always clean the appliance at regular intervals (about 1 year).
23. Wooden frames can not be used for the appliance in the kitchen in some locations where it is prohibited by the local fire department. In that case, the optional nonflammable frame must be used.
24. Operating the appliance in a dusty place could result in increased vibration or shorter bearing life depending on the dust, even though the configuration of the blade and shaft pass, and the use of sealed bearings are designed to prevent dust from entering the bearing. Because it is known that any dust attached to the blade makes it out of balance, resulting in increased vibrations. Also, dust that has come in through the shaft pass or the drain hole in the motor bracket could shorten the life of the bearings. Inspect and / or replace the motor ahead of time.
25. When operating the appliance in a humid place, install the appliance as follows: One of the drain plugs (or caps) must be placed on the underside of the motor, and the drain plug (or cap) must be removed. (However, the drain plug (or cap) should be attached when the appliance is installed in a dusty place. In such a case, Inspect it at intervals with the plug (or cap) removed.)
26. Consult with our local dealer when the appliance is to be installed to run as part of equipment. The appliance should be installed in such a way that it can be readily maintained. If the appliance failure or ending its service life could cause another failure, a Fail-safe configuration (such as an alarm) must be provided. (Fail-safe: design that prevents another failure to occur.)
27. The motor shaft can be placed either horizontally or vertically (the motor can be placed above or under the blade). If the motor is placed with the blade facing downward, contact MITSUBISHI ELECTRIC SYSTEM & SERVICE Co., Ltd in order to transfer the built-in preload spring from blade side to opposite side.
28. This appliance can not be combined with an inverter.

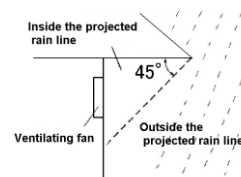

Third Angle Projection Method	Dim. in	Scale	Date	Model	HIGH PRESSURE FAN (EXHAUST TYPE) EWF-50FTA40A	
	mm	Non proportional	Oct. 2020			
MITSUBISHI ELECTRIC CORPORATION				Number	NJ014002-60-B (2/2)	Specification